

Electronic Deadbolt Door Lock - Classic

SH535-OR-1, SH535-SN-1

Part List

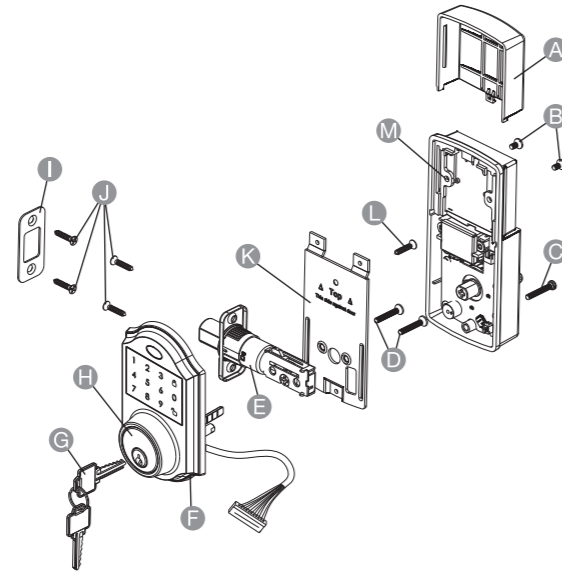

- | | |
|------------------------------|--------------------------------------|
| A Battery cover | H Touch keypad assembly |
| B 5/16" (8 mm) Screws | I Strike plate |
| C 1" (25 mm) Screw | J 3/4" (19 mm) Screws |
| D 7/8" (22 mm) Screws | K Mounting plate |
| E Latch | L Optional 3/4" (19 mm) Screw |
| F Rubber | M Interior assembly |
| G Keys | |

Contents:

Before getting started, ensure the package contains the following components:

- Interior hardware
- Mounting plate x1
 - 1-1/8" (28 mm) Screws x2
 - Optional 3/4" (19 mm) screw x1
 - Interior assembly w/ battery cover x1
 - 5/16" (8 mm) Screws x2
 - 1" (25 mm) Screw x1
- Exterior hardware
- Lock body w/ rubber gasket x1
 - Keys x2
- Door hardware
- Deadbolt latch x1
 - Deadbolt cover plate x1
 - Strike plate x1
 - 3/4" (19 mm) Phillips head wood screws for strike plate x2
 - 3/4" (19 mm) Phillips head wood screws for strike plate x2

Recommended Tools

- 1" (25 mm) Wood drill bit
- 2-1/16" (54 mm) Hole saw
- Level
- Screwdriver
- Hammer
- Pencil
- Tape measure
- Safety glasses
- Tape
- Wood chisel and/or router
- Drill
- 1/16" (2 mm) Drill bit

Before First Use

- Check for transport damage.
- ⚠ DANGER Risk of suffocation!** Keep any packaging materials away from children – these materials are a potential source of danger, e.g. suffocation.

Installation

Step 1: Mark Door

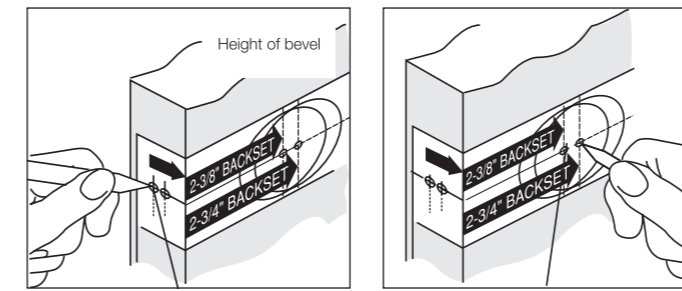

- Fold the template at the dotted line and tape the template onto the interior side of the door 34" to 48" (86 to 122 cm) from the finished floor.
- Measure the thickness of the door and mark either the 1-3/4" or 1-3/8" (44 or 37 mm) hole.
- Mark either the 2-3/8" or 2-3/4" (60 or 70 mm) hole for the backset.

Installation

Step 2: Drill Holes

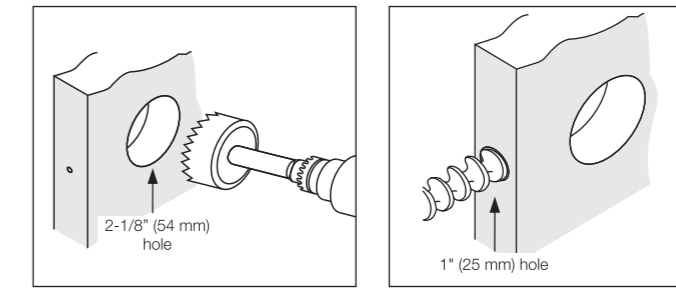

- Drill a 2-1/8" (54 mm) hole through door face as marked for the lock body.
- Drill a 1" (25 mm) hole in the center of the door edge for the latch.

Step 3: Install Latch Plate

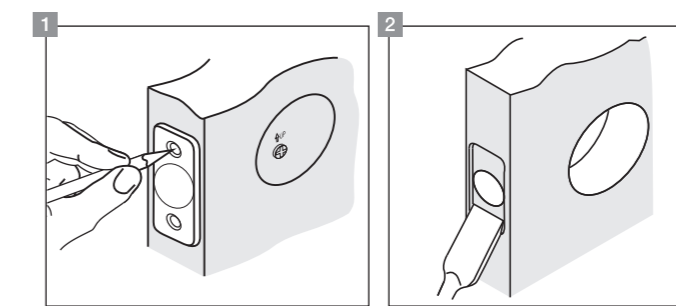

1. Slide the latch through the latch face plate.
2. Insert the latch into the hole, keeping it parallel to the door face. Outline face plate with a pencil and remove the latch.

Step 3: Install Latch Plate

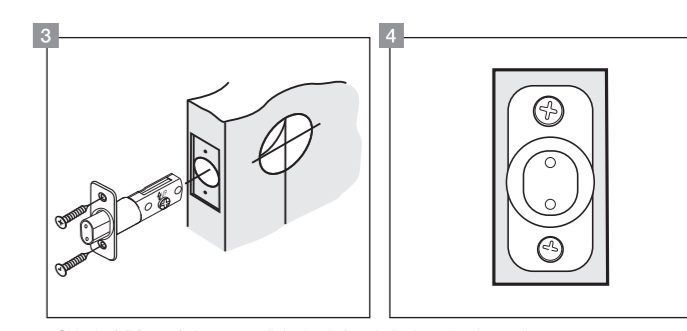

3. Chisel 1/8" (3 mm) deep or until the latch face is flush to the door edge.
4. Insert latch and tighten screws.

Step 4: How to Adjust the Latch

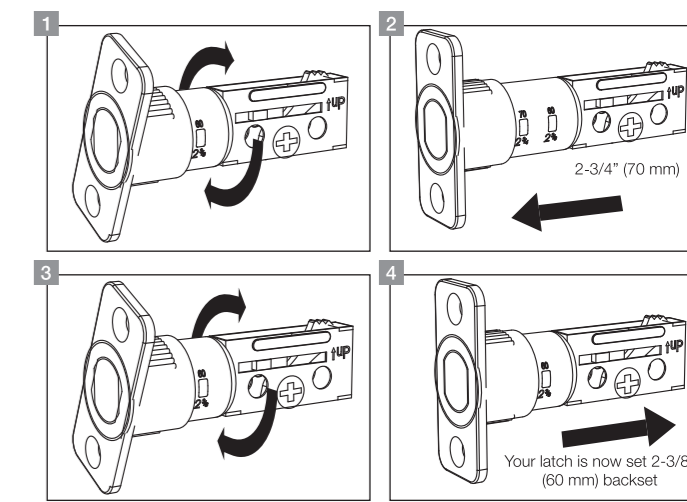

Step 4: How to Adjust the Latch

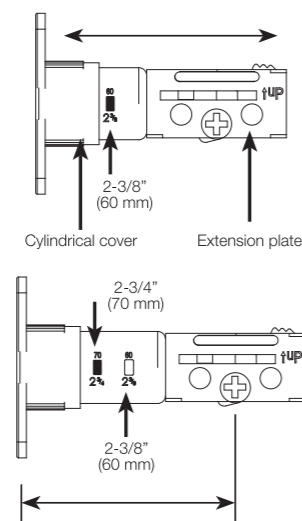

- To change the latch backset from 2-3/8" (60 mm) to 2-3/4" (70 mm):
- Make sure the side with the arrow and word "UP" is facing you.
 - Rotate the cylinder cover clockwise.
 - Pull the extension plate all the way out.
 - Rotate the cylinder cover counterclockwise until the tab locks into place. (You will hear a click.)

- To change the latch backset from 2-3/4" (70 mm) to 2-3/8" (60 mm):
- Make sure the side with the arrow and word "UP" is facing you.
 - Rotate the cylinder cover clockwise.
 - Push the extension plate all the way in.
 - Rotate the cylinder cover counterclockwise until the tab locks into place. (You will hear a click.)

Step 5: Install Striker Plate

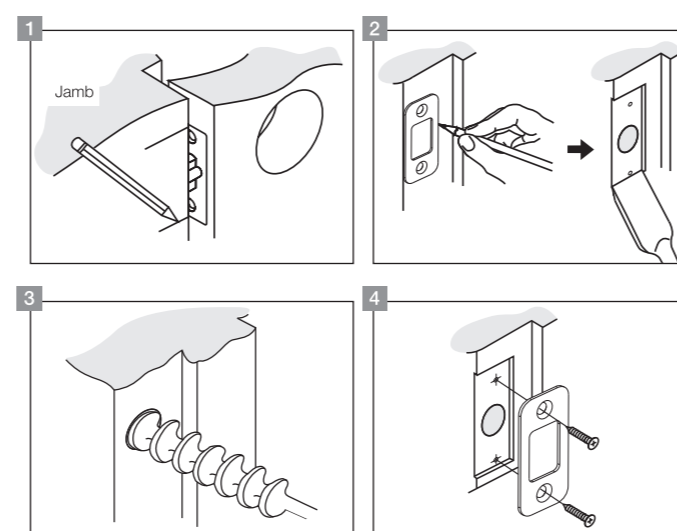

1. With the latch assembly installed partially close the door until the latch assembly is just inside the door jamb. Mark 2 lines on the face of the door indicating the top and bottom of the latch plate. Measure 1/4" (5 mm) inward from the door stop. Using the striker plate, align it with the lines and draw around the strike plate and mark your hole locations.
2. Drill a 1" (25 mm) hole that is 1/2" (13 mm) deep into the door jamb on the centerline of the screws.
3. Chisel 1/8" (4.2 mm) deep or until latch face is flush with door edge.
4. Install strike plate and tighten screws.

Step 6: Identifying Your Door Handing

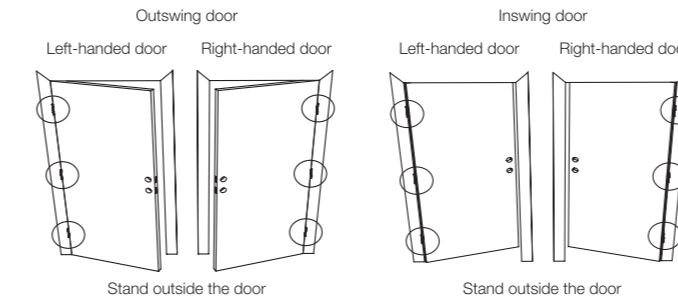

- If the hinges are on the left, then your door is left-handed.
- If the hinges are on the right, then your door is right-handed.

⚠ NOTICE You are standing outside the door.

Step 7: Preparing the Interior Assembly

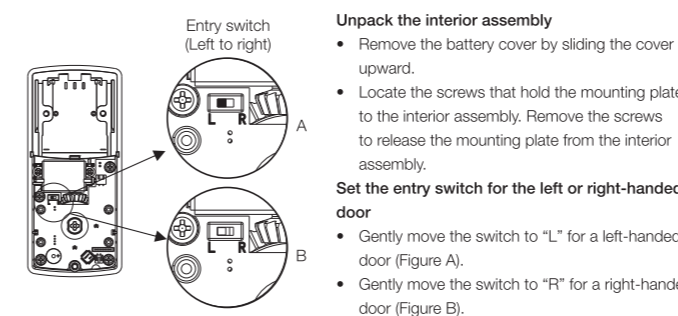

- Unpack the interior assembly**
- Remove the battery cover by sliding the cover upward.
 - Locate the screws that hold the mounting plate to the interior assembly. Remove the screws to release the mounting plate from the interior assembly.
- Set the entry switch for the left or right-handed door**
- Gently move the switch to "L" for a left-handed door (Figure A).
 - Gently move the switch to "R" for a right-handed door (Figure B).

Step 8: Install the Exterior Mechanism

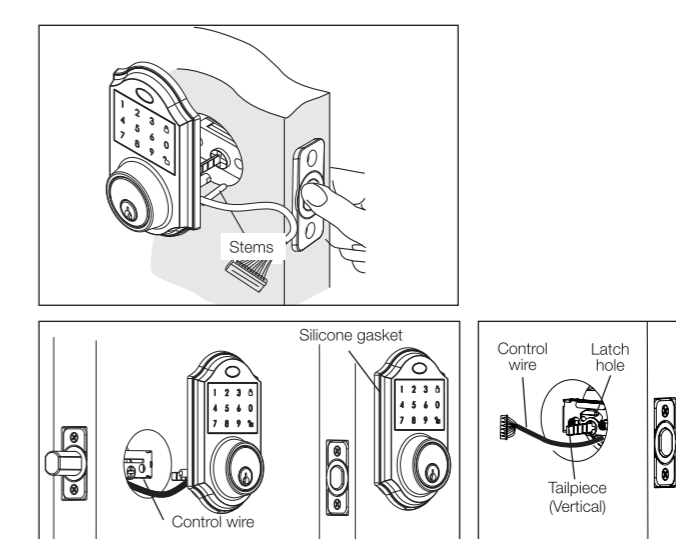

- ⚠ NOTICE** Work with the door open for easy access.
- Be careful to not scratch or damage the green circuit board during handling and installation.
- Check if the rubber gasket is seated properly around the lock body.

- ⚠ NOTICE** Make sure the tail piece on the lock body is in vertical position before installing.
- Insert the tail piece of the lock body through the dead bolt set cross shaped spindle connector and push the lock body up against the door.

- ⚠ NOTICE** When installing the lock body, make sure the key pad is facing up.
- Route the control wire through the door under the latch bolt.

Step 9: Install Exterior Assembly

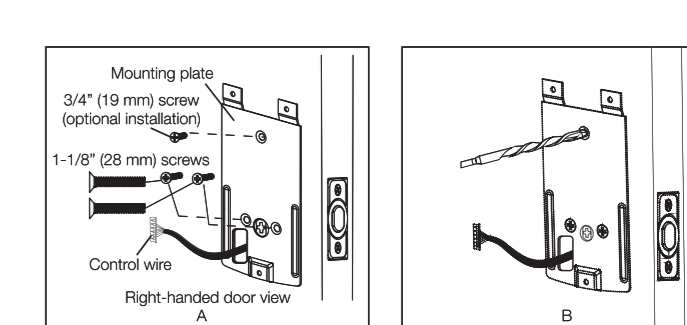

- Securing the exterior assembly to the door**
- From the side marked "this side against door", route the control wire through the rectangular slot in the mounting plate.
 - Place the mounting plate against door with the tailpiece passing through the middle hole in the set of three hole (Fig. A).
 - Secure the mounting plate to the exterior assembly using two 1-1/8" (28 mm) screws.
 - Hand-tighten with a screwdriver, leaving the screws loosely-tightened (Fig. A).
 - Check the vertical alignment of the mounting plate (Fig. A).
 - Securely tighten with a screwdriver. Do not over-tighten.

- Optional installation**
- Using a 1/16" (2 mm) drill bit, drill a pilot hole in your door using the mounting plate upper hole as a guide (Fig. B).
 - Insert one 3/4" (19 mm) screw and tighten.

- ⚠ NOTICE** Lock and unlock using the key to see if the deadbolt latch is easily closed and opened.

Installation

Step 10: Preparing the Interior Assembly

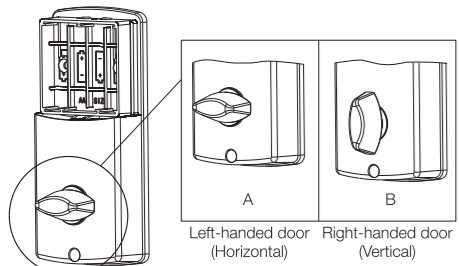

- Set the interior knob position for left or right-hand hinged doors**
- The interior knob goes to the horizontal position for left-handed doors (Fig. A).
 - The interior knob goes to the vertical position for right-handed doors (Fig. B).

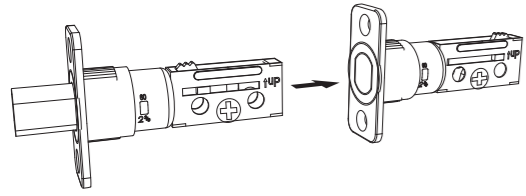

NOTICE Make sure the deadbolt latch is retracted.

11

Step 11A: Installing the Interior Assembly

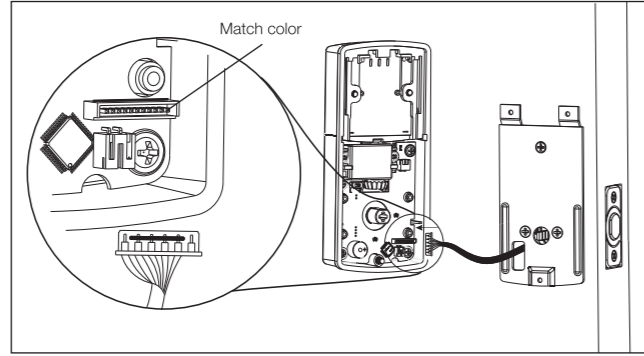

Attach the control wire to the interior assembly

- Carefully attach the control wire male plug to the interior assembly female socket connector.
- The control wire male plug has two alignment tabs on the smooth side of the plug.
- The control wire male plug is inserted (with the smooth side up), into the interior assembly female socket connector.

NOTICE Do not force the control wire male plug into the interior assembly female socket connector.

12

Step 11B: Installing the Interior Assembly

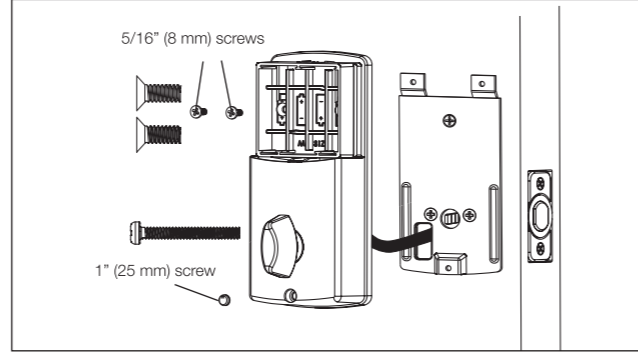

Attach the interior assembly to the door

- Position the interior assembly over the tailpiece and push the interior assembly against the door.
- Using two 5/16" (8 mm) screws and one 1" (25 mm) screw, attach the interior assembly to the mounting plate. **DO NOT OVERTIGHTEN THE SCREWS.**

NOTICE Lock and unlock using the interior knob to see if the latch is easily closed and opened.

13

Step 12: Installing the Interior Assembly

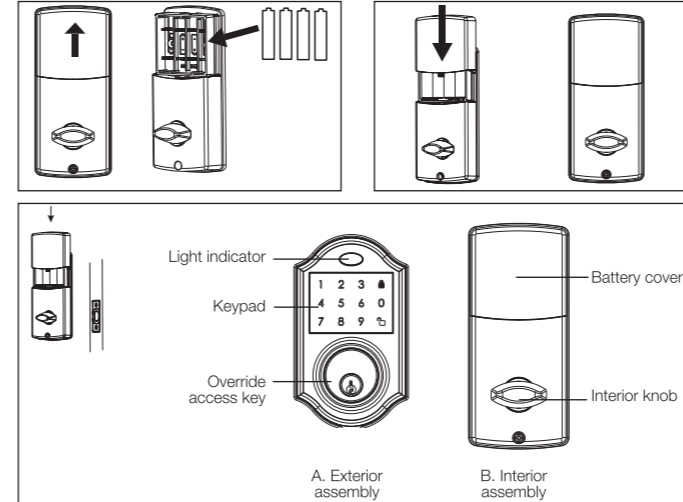

Installing batteries

- Insert 4 high-quality AA alkaline batteries into the battery compartment in the direction noted +/- on the compartment. The lock will beep twice, the keypad will illuminate blue, and the light indicator will flash green twice to signify that it has received power (Fig. A).
- Slide the battery cover downwards, along the tracks on the interior assembly, to cover the batteries (Fig. B).

NOTICE Do not touch the keypad until the blue light turns off. Do not use rechargeable batteries or non-alkaline batteries.

Testing the lock with the door open

- Test the lock using the interior knob. The bolt should move smoothly. Test the lock using the keypad. To lock, press **Lock** and then press "1234" **Unlock**.

14

Keypad Overview

Light indicator

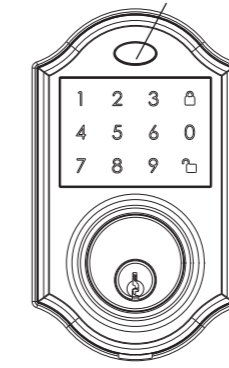

Red

- Indicates failed programming step.
- Indicates locking is successful.

Lock button

- Lock - Used to lock door
- Clear - Used to clear wrong keypad entries

Unlock button

- Unlock - Used to unlock door
- Programming - Used in programming steps

Factory settings (new)

The lock comes with factory preset settings:

Programming code = 123456

User code = 1234

User ID = 01

NOTICE Please change the programming installation to ensure security.

Green

- Indicates successful programming step.
- Indicates unlocking was successful.

Batteries (not included)

- Electronic lock requires 4 high-quality AA alkaline batteries.
- When all 4 batteries are installed in the correct position, you will hear 2 beeps and the keypad will illuminate blue. Do not touch the keypad until the keypad stops illuminating.

Programming Symbols

Lock / clear

User code (4-8 digits)

Unlock / programming

User ID (01-50, 2 digits)

Programming code

NOTICE Change the programming code and the user code as soon as possible after installation to ensure security.

15

Operation

Programming Tips

5 Seconds

- Complete all the programming steps in the programming mode within 5 seconds.

Clear

- Use the **Clear** key to clear entries in case a wrong button is pushed.

Locking and Unlocking

To unlock the lock

- Using the keypad: Enter a valid user code (default code is 1234) and press **Unlock**. A beep will be heard and the indicator will illuminate in green.

To lock the lock

- Using the keypad: Press **Lock**, then hear 2 beeps and the indicator will illuminate in red.

Changing Programming Code

Change current or preset programming code

- Factory default programming code is 123456. This is the master password for your lock. All programming functions require this code. Follow the sequence below to change the programming code to your custom 6-digit combination.

For example

- To change the programming code = 23456, enter the following:

123456 → 4 → new → 23456 → re-enter → 23456

Hear 1 beep and the light indicator illuminates in green.

To changing programming code = 23456, enter the following:

Operation

Adding User Codes

To add a new user code (you can add up to 50 new user codes)

- The user code must be a 4-8 digit combination. Each user code is then linked to a user ID (which is any number between 01-50), to identify an individual user code. (User ID 1-9 should be entered as 01-09 so they are 2 digits.)

For example

- To add the User ID = 08 to user code = 3456, enter the following:

23456 → 1 → 08 → 3456 → re-enter → 3456

Hear 1 beep and the light indicator illuminates in green.

NOTICE When a NEW USER CODE is set, the default factory code (1234) is deleted for safety purposes.

Deleting User Codes

Delete one existing or preset user code

(The unit comes with a factory user ID = 01 for user code = 1234)

NOTICE To delete 1 user code, the lock must have more than 1 user code in its database.

23456 → 2 → existing → 08 → re-enter → 08

Hear 1 beep and the light indicator illuminates in green.

Delete all user codes

NOTICE This will delete the user codes, but not the programming code. Enter the following.

23456 → 3 → re-enter → 123456

Hear 1 beep and the light indicator illuminates in green.

17

Automatic Lock Function

Set or cancel Auto-lock

- You can set the lock to automatically close each time after the lock is opened.

Time value range = 20-900 seconds. Enter the following:

Set auto-lock: 123456 → 5 → time value → 20

Hear 1 beep and the light indicator illuminates in green.

To cancel auto-lock, set the time to 00. Enter the following:

123456 → 5 → 00

Hear 1 beep and the light indicator illuminates in green.

Temporarily Disable Auto-lock

Disable

- While in auto-lock mode, unlock the door using **Unlock**. Within 10 seconds, you must turn the locking knob by hand to the locked position, wait for more than 2 seconds, then turn the locking knob back to the unlock position. The auto-lock mode is now disabled.

Restore

- To restore the auto-lock function, you can turn the locking knob by hand to the locked position, wait more than 2 seconds or press the **Lock** button on the keypad.

Turn On/Off Sound

You can mute or turn lock sound on by entering the following.

(Factory setting is sound on.)

123456 → 6 → 1 or 2

1 = sound off

2 = sound on

Sound off (1) - light indicator illuminates in green.

Sound on (2) - Hear 1 beep and light indicator illuminates in green.

18

Vacation Mode

With vacation mode enabled, the system enters into low-power consumption mode. During this mode, all buttons and functions—including the remote control—will be invalid until they are re-enabled (see steps below).

Enable: 123456 → 10 → 1

Hear 1 beep and the light indicator illuminates in green.

Disable: To disable the vacation mode, you must press and hold **Unlock** for more than 3 seconds, then input **Unlock** to unlock the door. Vacation mode is now disabled.

NOTICE If you only press the **Unlock** for more than 3 seconds, but do not input **Unlock**, the system will remain in vacation mode.

Secure Lock-Out Period

Warning alert sounds and LED flashes red after 4 incorrect code attempts:

Keypad shuts down for 60 seconds.

Restore Factory Settings

To reset the lock to the original factory settings, including the programming code and all user codes, remove one battery for 10 seconds. Reinsert the battery and wait for one long beep followed by a short beep. Press **Lock** 3 times within 3 seconds. The lock will beep and the light indicator will turn green.

Low Battery Warning

Beeps and LED flashes red for 5 seconds. Replace with good-quality alkaline batteries.

NOTICE Removing batteries does not erase active programming or user codes.

19

Audio and Visual Message Guide

Unlock / Valid programming:	1 long beep and LED illuminate in green
Lock:	2 short beeps and LED illuminates in red
Invalid Programming:	2 short beeps and LED flashes red twice
Low Voltage:	Beeps for 5 seconds (about 7 or 9 times, depending on whether the operation is unlock/lock)
Super Low Voltage:	4 short beeps and LED flashes red four times
4 Incorrect code entry attempts:	2 short beeps and LED illuminates in red for each attempt
Power on:	1 long beep and 1 short beep and LED illuminates green
Chip Reset:	1 long beep followed by a 1 short beep and LED illuminates green. (May occur several times or once in a while.)
Lock Error:	3 long beeps and LED flashes red three times
Operation is repeated after Lock Error:	2 short beeps three times LED flashes red six times

NOTICE When the battery is under low voltage, the lock will alert with a warning indicating low battery. (The lock beeps and flashes red for 5 seconds.) During this time, your lock will still work. However once the voltage is lower than 4.3 V (called super - low voltage), the operation of the locking and unlocking will not work and user must replace batteries immediately.

20

Troubleshooting

Issue	Solution
The latch is working backwards. The lock unlocks when the lock button is pushed or locks when the unlock button is pushed or unlock code is entered.	The direction switch have incorrect settings. Remove the interior assembly and move the switch to the opposite direction. <ul style="list-style-type: none"> Check that your switch is set to the correct position for left or right-handed doors. If correct <ul style="list-style-type: none"> Rotate the interior knob and reinstall interior assembly. Retest again while holding the assembly in place.
The interior knob will not turn.	The knob or vertical tailpiece is installed in incorrect position. Remove the interior assembly and reposition the interior knob. With the deadbolt latch retracted verify that the tailpiece is vertical. <ul style="list-style-type: none"> Check that all batteries are new, high-quality alkaline batteries. Check for proper polarity (+ -) of all the batteries. Check that the control wire is attached to the interior assembly.
The lock will not function electronically.	Unlock door using the key or interior knob. While the door is open, check that the deadbolt latch operates smoothly. Check for proper alignment of the strike plate. Adjust as needed to assure there is no binding against the deadbolt latch. <ul style="list-style-type: none"> Check that all batteries are new, high-quality alkaline batteries. Check for proper polarity (+ -) of all the batteries. Check that the control wire is attached to the interior assembly. Reattach control wire and interior assembly.
Deadbolt latch is sticking.	Installation screws of the lock may be too tight and have to be loosened. <ul style="list-style-type: none"> Remove interior assembly. Slightly loosen the mounting plate screws. Lock and unlock using the key. Reattach control wire and interior assembly.
Lock gives error signal when opening or locking and the deadbolt latch will not extend or retract completely when door is closed.	Unlock door using the key or interior knob. While the door is open, check that the deadbolt latch operates smoothly. Check for proper alignment of the strike plate. Adjust as needed to assure there is no binding against the deadbolt latch.

Battery Disposal

Do not dispose of used batteries with your household waste. Take them to an appropriate disposal/collecton site.

Made in China

21

Template

