

# SOUTH MAIN HARDWARE

## INSTRUCTION MANUAL Ball Bearing Full-Extension Drawer Slides SLIDE-BB

**NOTICE:** These slides are for frameless cabinets. Face-frame cabinets will require a face-frame kit.

 **STOP:** Please carefully READ instruction manual before beginning your installation.

### Product Specifications:

- These premium ball bearing slides are designed for use on office file drawers, bedroom furniture, and kitchen cabinets.
- Made from cold rolled steel. Each pair has a weight capacity of 100 lbs.
- This item is available in the following lengths: 10", 12", 14", 16", 18", 20", and 22".
- **IMPORTANT:** Avoiding drawer binding, drawer must be 1/2" narrower than the opening on each side of the cabinet.
- Top and bottom of drawer should have 1/8" minimum clearance from cabinet opening.

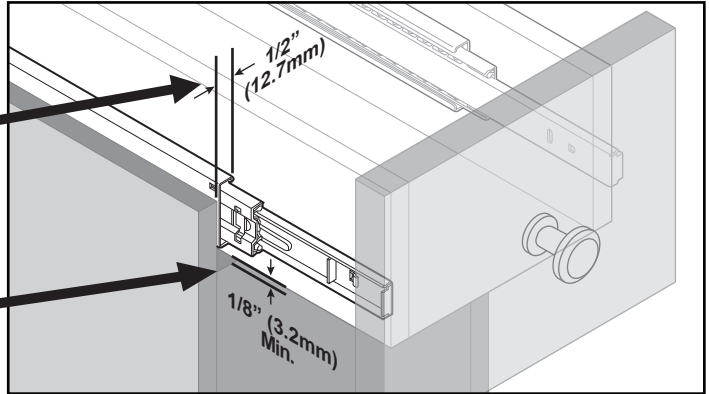

### Recommended Tools:

- Phillips screwdriver
- Tape Measure
- Pencil
- Level

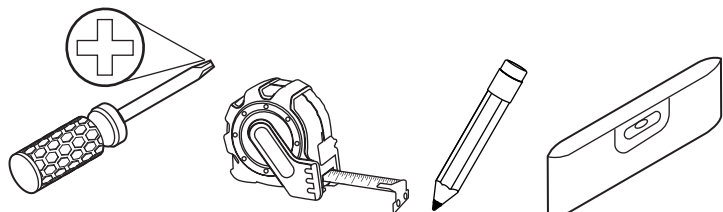

## What's included:

- (A) Two (2) Cabinet Members
- (B) Two (2) Drawer Members
- (C) Twelve (12) #6 1/2" Pan Head Wood Screws

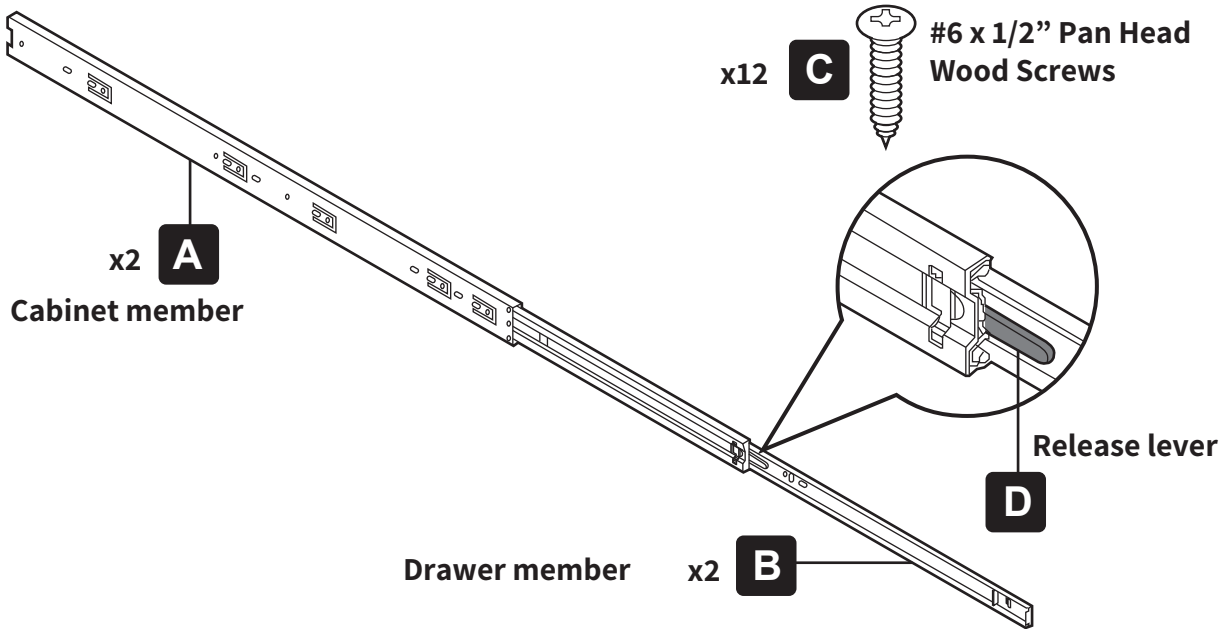

## Installation Guide:

### Step 1: Detaching the Drawer Member

With slide fully extended, remove the drawer member (B) from the cabinet member (A) by pushing up on the drawer member lever (D).

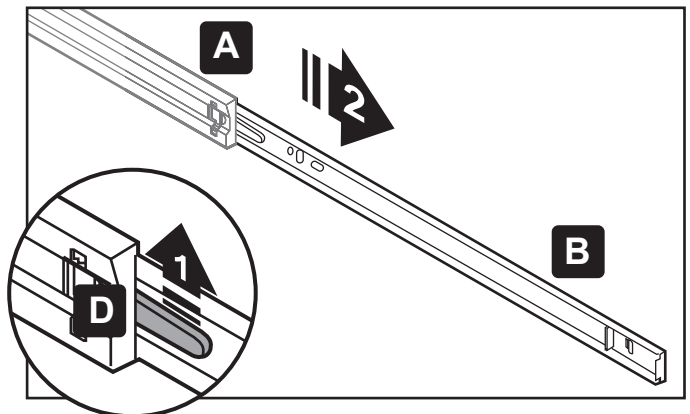
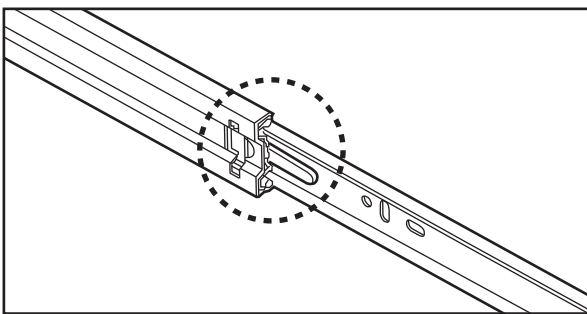

## Step 2: Marking and Aligning Drawer Member (B)

Mark a line 1-1/4" (31.8mm) from the bottom of the drawer. Align the top of the drawer member (B) with the marked line.

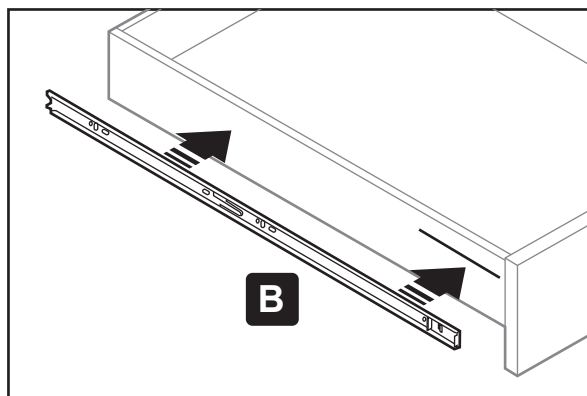
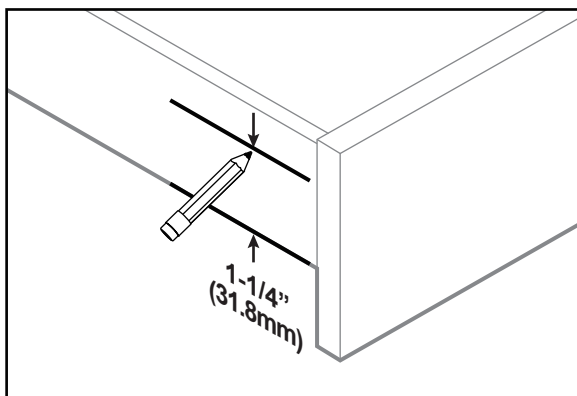

## Step 3: Installing Drawer Member (B)

1. Using a level, ensure the drawer member (B) is properly aligned with marked line 1-1/4" line.
2. Attach drawer member using provided screws.
3. Repeat steps 1-3 to install remaining drawer member (B).

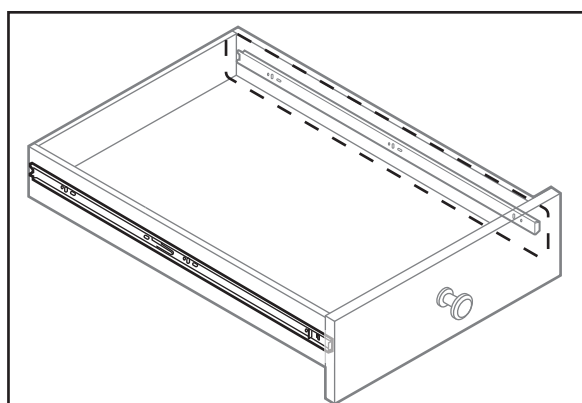
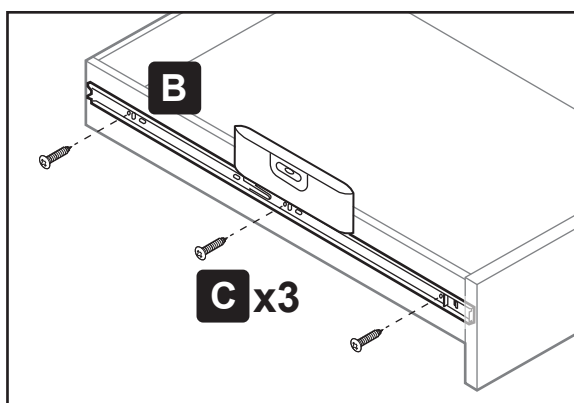

## Step 4: Determining Drawer Position

1. Align drawer to desired location. Mark a line on the cabinet at the bottom of the drawer face on both sides.
2. Reattach cabinet member (A) to drawer member (B).

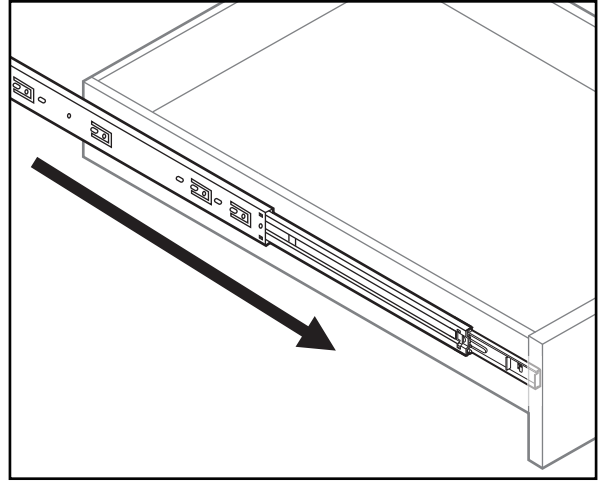
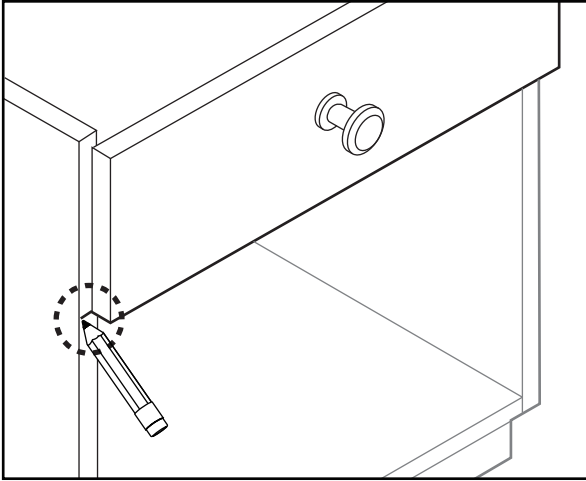

3. Once attached, measure the distance between the bottom of the drawer front to the top of the cabinet member (A). Write down this measurement "X".

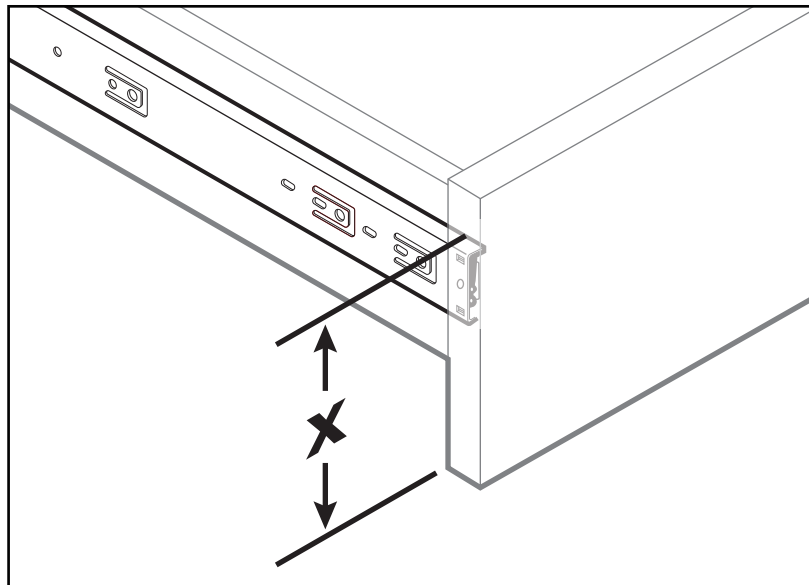

## Step 5: Installing Cabinet Member (A)

1. Remove cabinet member (A) from drawer.
2. Measure distance "X" from the previous cabinet mark. Draw a line inside the cabinet wall to mark this distance.

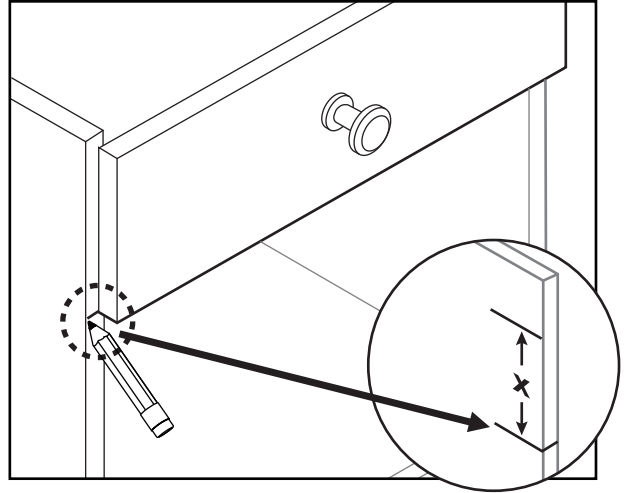
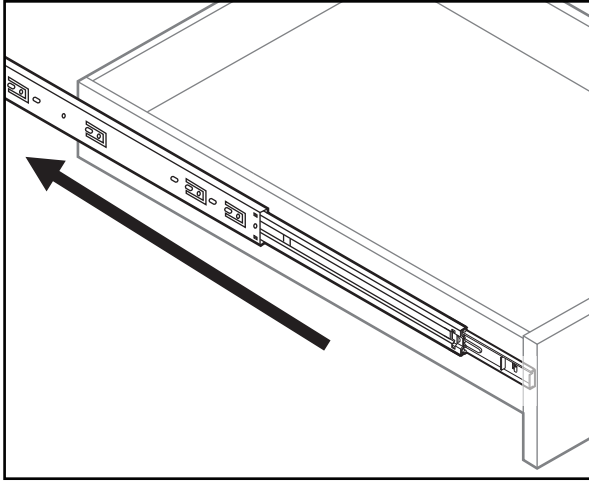

3. Position top of cabinet member (A) with new mark.
4. IMPORTANT: Make sure the member is mounted 1/16" (1.6mm) from the front of the cabinet.

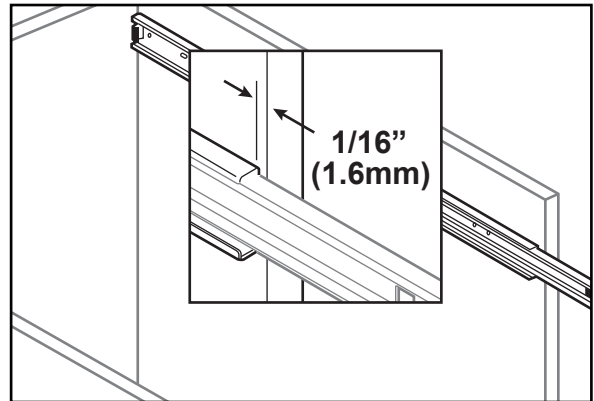
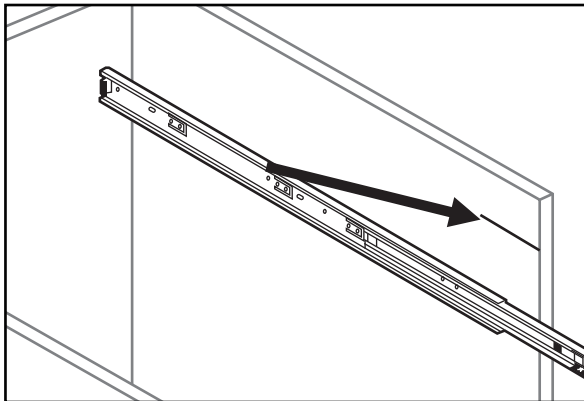

5. Align with level before securing with the provided screws.

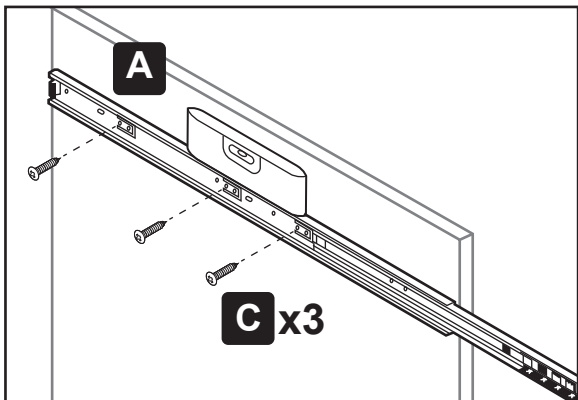

6. Repeat steps 4 and 5 to install remaining cabinet member (A).

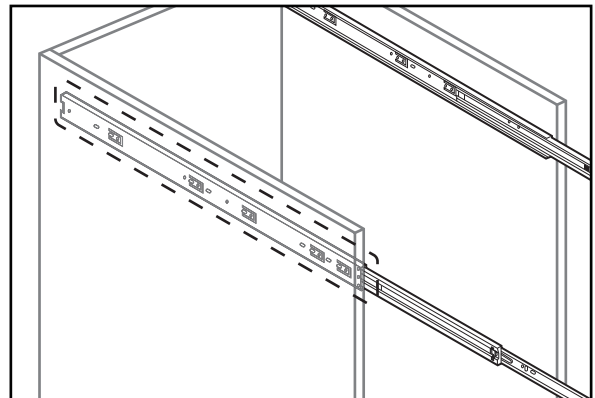

# Step 6: Connecting your Drawer

To attach your drawer to the cabinet, simply align and slide drawer members into cabinet members. Releasing levers will click and automatically lock as you attach drawer. Test drawer to ensure proper installation. Enjoy!

